

601 SLITTER

The model 601 slitter is designed for slitting heavy weight carpets and textiles at high line speeds. The 601 slitter is based upon a twin blade scissors action principle of cutting. One blade is positive driven and one blade is frictional driven, so any width material may be slit.

The motor is a one horsepower gear motor. Different RPM output speeds are used to match the blades circumference speed to the customer's fastest line speed. For long shaft life, the blade shaft has two hardened inner-races which run in needle bearings.

Slitter mounting is achieved by four 3/8-16" tapped holes in the base. Trolleys are available for mounting on 6" 20 pound beams. A single slitter weighs 140 lbs. The 601 slitter will offer reliable trimming at high line speeds.

For more information on the 601 slitter contact:
TEXTILE AND INDUSTRIAL SALES INC.

P.O. BOX 768 404 WHITENER DRIVE

DALTON GEORGIA 30722 U.S.A.

TELEPHONE 706-226-2102

FAX 706-278-1734

EMAIL tisi@alltel.net

VISIT OUR WEBSITE: www.texindsls.com

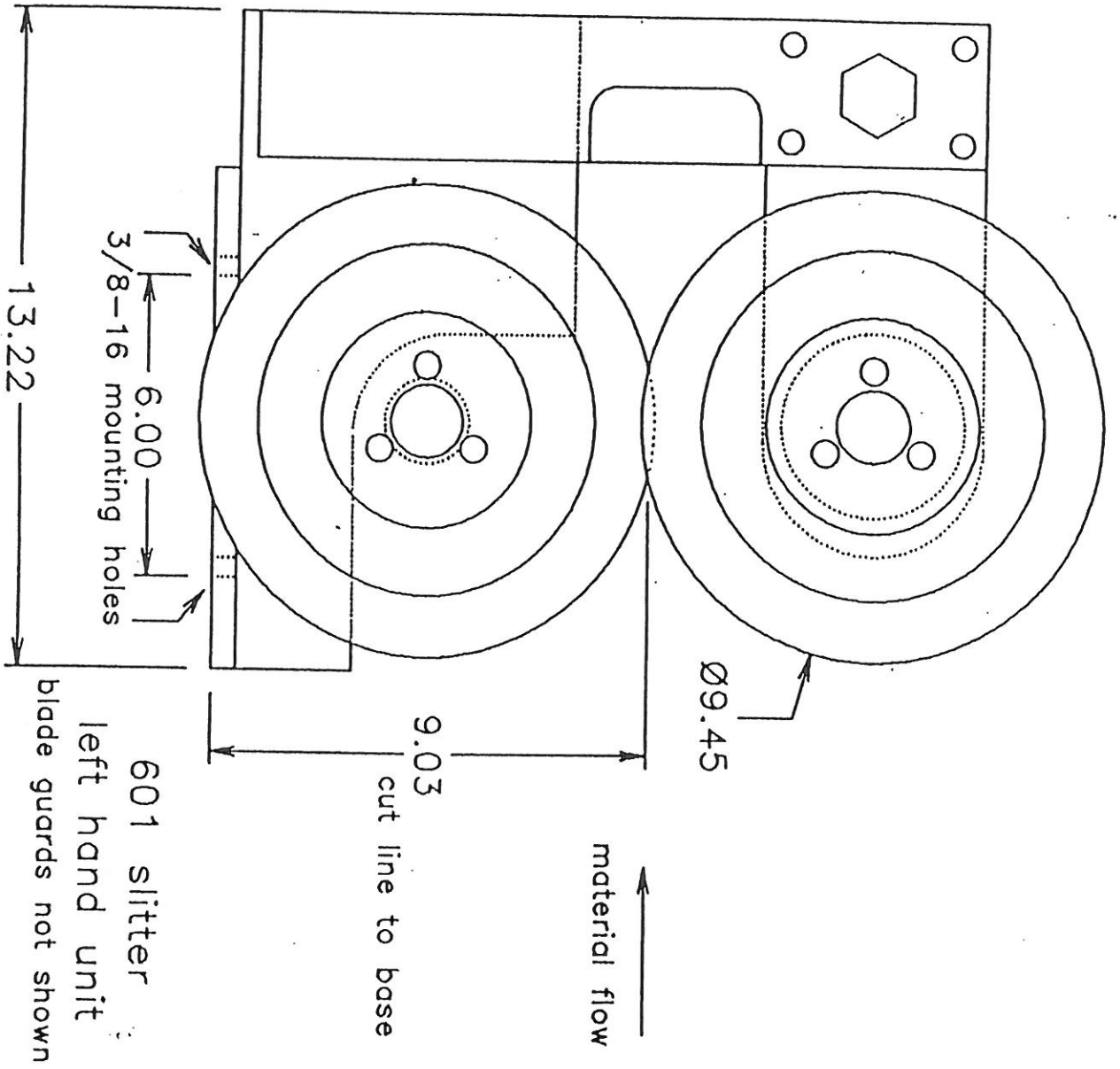

601 slitter
 left hand unit
 blade guards not shown

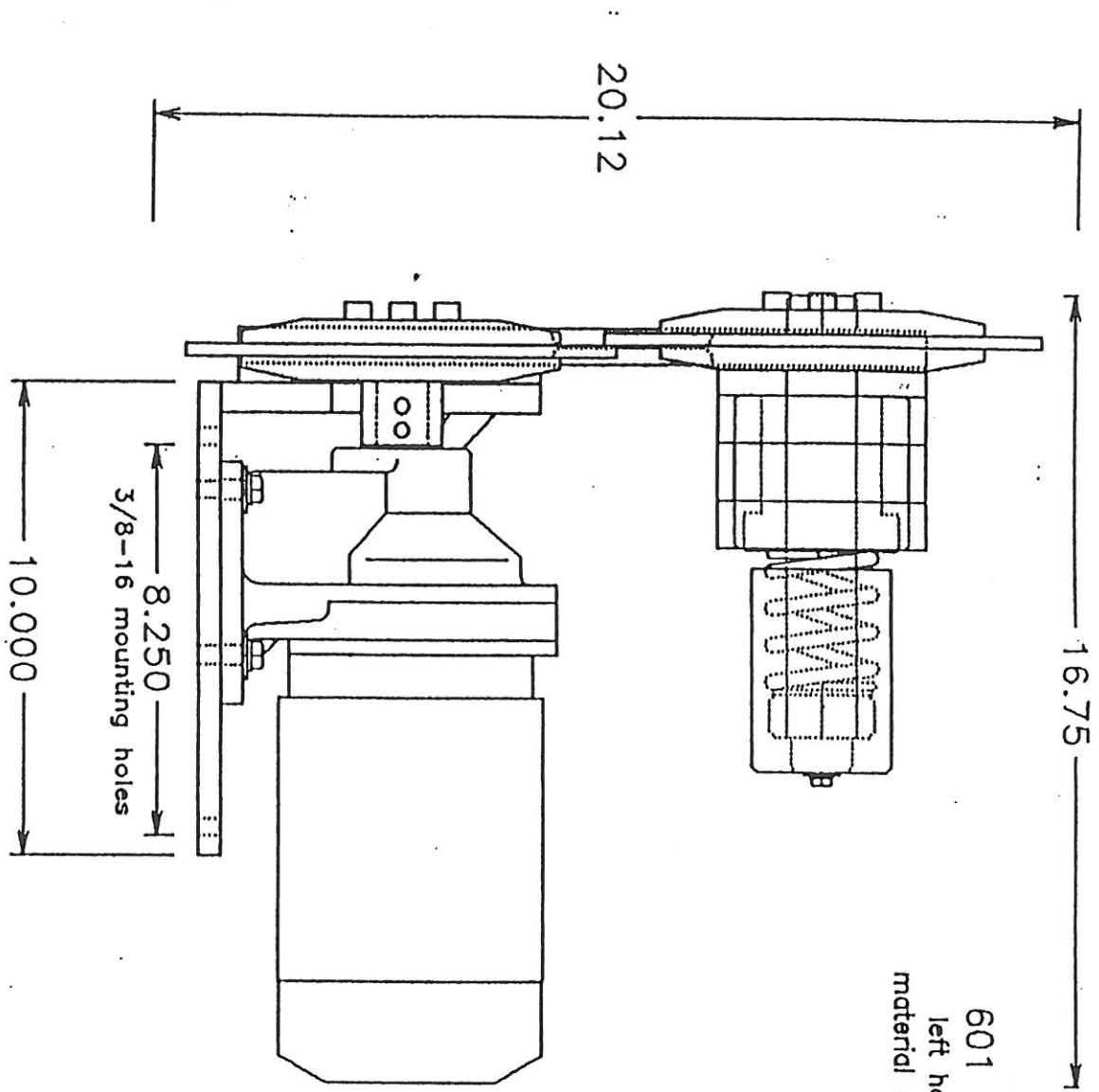

601 slitter
left hand unit
material entrance end